



THE A2512 ACCELEROMETER HAS BEEN DESIGNED FOR DYNAMIC STRUCTURAL TESTING IN TOUGH FIELD CONDITIONS WHERE LONG CABLE LENGTHS ARE REQUIRED. THESE ACCURATE, RUGGED, AND FULLY-WEATHERPROOFED INTEGRATED MEMS SENSORS CAN BE USED FROM ZERO TO MEDIUM FREQUENCY APPLICATIONS THAT REQUIRE LOW NOISE AND RELIABLE LONG-TERM STABILITY. AVAILABLE IN UNI, BI, AND TRI-AXIAL VERSIONS, EACH MODEL CAN BE INSTALLED VERY QUICKLY AND IS AVAILABLE IN RANGES BETWEEN $\pm 2g$ AND $\pm 100g$.

FEATURES

- + Completely reusable
- + Designed to exceed IP67
- + Nitrogen gas damped
- + High stability
- + Low power requirements
- + Various mounting options available
- + Industrial cable, custom lengths
- + N.I.S.T. traceable calibration available
- + 9-30 Vdc input voltage range
- + High differential output (± 2.0 Vdc)
- + Responds down to 0 Hz

APPLICATIONS

- + Cable force measurements
- + Structure vibration testing & monitoring
- + Earthquake monitoring/detection
- + Structure modal analysis
- + Vehicle dynamics
- + Impact detection
- + Long lead cable (up to 1,500 ft/460 m)

DIMENSIONS

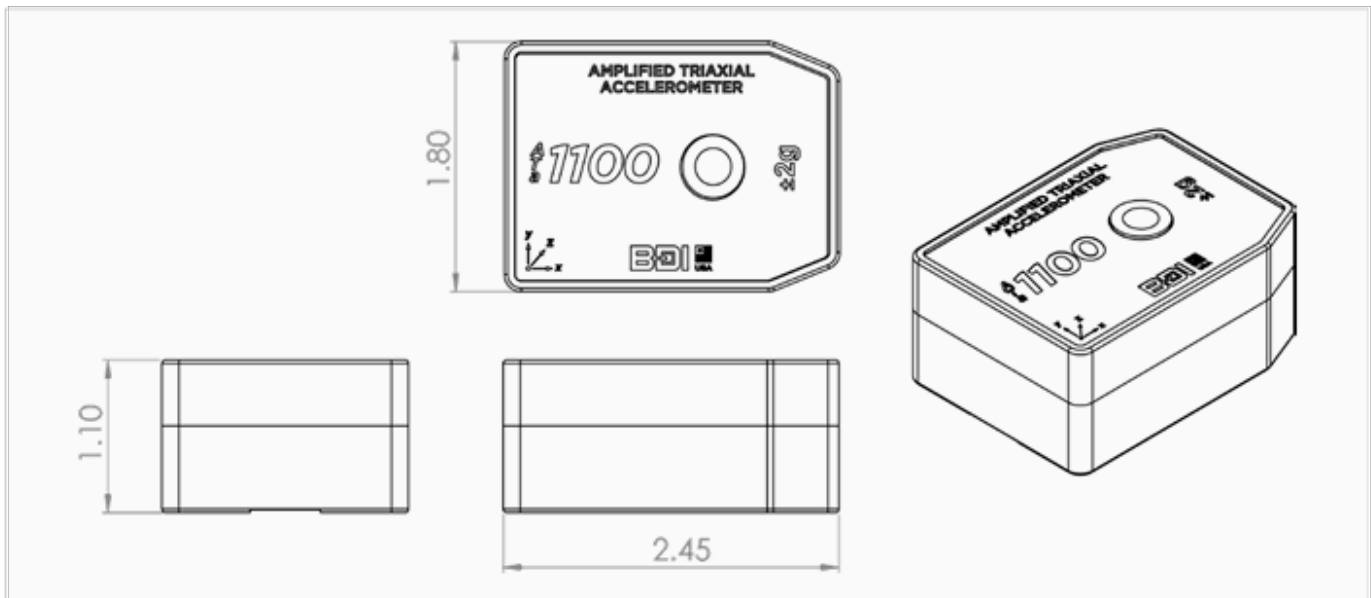

SPECIFICATIONS

UNIAXIAL MODELS BIAxIAL MODELS TRIAxIAL MODELS	U A2512-002 B A2512-002	U A2512-005 B A2512-005 T A2512-005	U A 2512-010 B A2512-010 T A2512-010	U A 2512-025 B A 2512-025 T A 2512-025	U A2512-050 B A 2512-050 T A 2512-050	U A2512-100 B A2512-100
RANGE (g) ¹	±2	±5	±10	±25	±50	±100
FREQUENCY RESPONSE [NOMINAL, 3dB] (Hz)	0-300	0-400	0-600	0-900	0-1200	0-1400
DIFFERENTIAL SENSITIVITY (mV/g)	2000	800	400	160	80	40
OUTPUT NOISE, DIFFERENTIAL [rms, TYPICAL] (µg/√Hz)	7	12	18	25 5000	50	100
MAX MECHANICAL SHOCK [0.1 ms] (g)	2000					
TYPE	Micro-machined capacitive sense element					
DAMPING	Nitrogen Gas Damped					
EXCITATION VOLTAGE	9-30 V _{dc}					
POWER RATING MAX (UNI, BI, TRI) TYPICAL (UNI, BI, TRI) INTELLIDUCER (UNI, BI, TRI) ²	38mW, 75 mW, 112 mW 25mW, 50 mW, 75 mW 13mW, 26 mW, 39 mW @ +5.0 V _{dc}					
OUTPUT IMPEDANCE	50Ω					
DIFFERENTIAL OUTPUT	±2.0 V _{dc} Full Scale Output					
OPERATING TEMPERATURE ³	-58° to +176 °F (-50° to +80 °C)					
SIZE	2.45 x 1.80 x 1.10 in (62.2 x 45.7 x 27.9 mm)					
WEIGHT	0.33 lb (149 g)					
HOUSING	Machined 6061 Aluminum Alloy					
CORROSION RESISTANCE	Hard Anodized Clear (MIL-A-8625 Type III)					
CABLE	Custom lead cable length made to order: IC-02-187 [22 AWG, 2 shielded pair, drain wire, red PVC jacket] IC-03-250 [24 AWG, 3 shielded pair, drain wire, black PVC jacket] IC-04-250 [24 AWG, 4 shielded pair, drain wire, black PVC jacket]					
WEATHER PROTECTION	Designed to exceed IP67					
CIRCUIT PROTECTION	ESD Protection (IEC 61000-4-2) Reverse polarity protection					
MOUNTING	Through holes for ¼ in (M6) bolts or anchors Reusable mounting tabs (gluing/welding)					
COMPLIANCE	ESD protection conforming to IEC 61000-4-2					
CROSS AXIS SENSITIVITY	Max ±3%, TYP ±2%					
BIAS TEMPERATURE SHIFT	±200 (PPM of Full Scale)/°C					
NON-LINEARITY -90 TO +90% OF FULL SCALE	Max 0.50%, TYP 0.15%					

¹ Higher ranges are available, contact BDI for more details

² Intelliducer connector required with STS4 Intelliducer data acquisition nodes.

³ Temperature limit based on instrumentation cable operating temperatures, call BDI for wide temperature range cable options.

OPTIONS & ACCESSORIES



Intelliducer Connector - Required for use with STS Intelliducer Nodes, cable is connected and potted for a weatherproof seal.



V-Notch Cable Mount - Machined aluminum 24 in (610 mm) gage length extension with 3.0 in (76 mm) increments



Reusable Mounting Tabs - ¼-20 or M6, zinc plated steel mounting tab.



Protective Covers - Insulated aluminum protective covers

Complete Instrumentation Solutions Private Limited,
Suite # 512, Suncity Business Tower, Golf Course Road, Sector-54, Gurgaon-122011, Haryana
Tel: 0124-4929000 | E-mail: info@instrumentation-solutions.com
www.instrumentation-solutions.com